

Patterns of Heredity and Human Genetics

What You'll Learn

- You will compare the inheritance of recessive and dominant traits in humans.
- You will analyze the inheritance patterns of traits with incomplete dominance and codominance.
- You will determine the inheritance of sex-linked traits.

Why It's Important

The transmission of traits from generation to generation affects your appearance, your behavior, and your health. Understanding how these traits are inherited is important in understanding traits you may pass on to a future generation.

Understanding the Photo

Inherited traits are the expressions of DNA codes found on chromosomes. The grandmother, father, and mother have DNA that is unique to each of them. However, the identical twin daughters have identical DNA and, therefore, inherited the same traits.



Biology Online

Visit bdol.glencoe.com to

- study the entire chapter online
- access Web Links for more information and activities on genetics
- review content with the Interactive Tutor and self-check quizzes

Section 12.1

SECTION PREVIEW

Objectives

Interpret a pedigree.

Identify human genetic disorders caused by inherited recessive alleles.

Predict how a human trait can be determined by a simple dominant allele.

Review Vocabulary
trait: any characteristic that is inherited (p. 253)

New Vocabulary

pedigree
 carrier
 fetus

Mendelian Inheritance of Human Traits



Pedigrees Make the following Foldable to help you understand the symbols used in a pedigree.

STEP 1 **Fold** a vertical sheet of notebook paper from side to side.

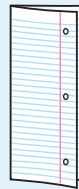

STEP 2 **Cut** along every fifth line of only the top layer to form tabs.



STEP 3 **Label** each tab.

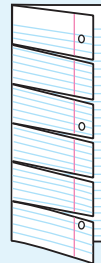

Use Models As you read Chapter 12, list the symbols that are used in a pedigree on the tabs. As you learn what each symbol means, write the meaning under the tab for each symbol.

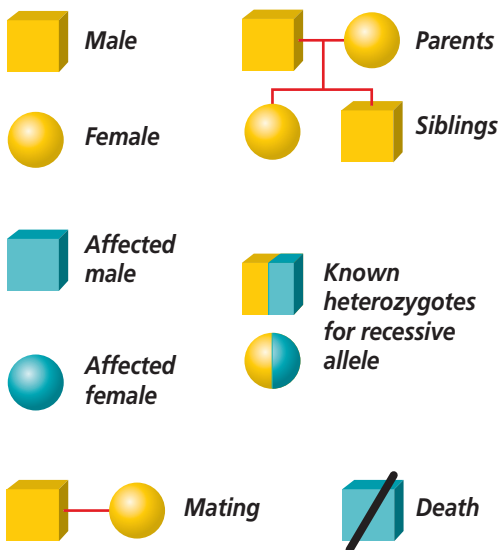

Figure 12.1
 Geneticists use these symbols to make and analyze a pedigree.

Making a Pedigree

At some point, you have probably seen a family tree, either for your family or for someone else's. A family tree traces a family name and various family members through successive generations. Through a family tree, you can identify the relationships among your cousins, aunts, uncles, grandparents, and great-grandparents.

Pedigrees illustrate inheritance

Geneticists often need to map the inheritance of genetic traits from generation to generation. A **pedigree** is a graphic representation of genetic inheritance. It is a diagram made up of a set of symbols that identify males and females, individuals affected by the trait being studied, and family relationships. At a glance, it looks very similar to any family tree. Some commonly used pedigree symbols are shown in *Figure 12.1*.

MiniLab 12.1

Analyze Information

Illustrating a Pedigree The pedigree method of studying a trait in a family uses records of phenotypes extending for two or more generations. Studies of pedigrees yield a great deal of genetic information about a family.

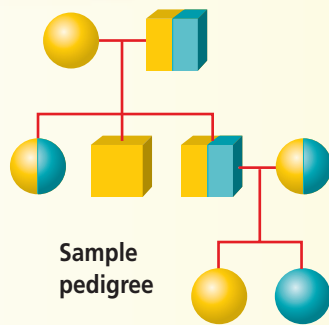

Procedure

- 1 Working with a partner at home, choose one human trait, such as earlobe types or tongue rolling, that interests both of you. Looking through this chapter might give you some other ideas.
- 2 Using either your or your partner's family, collect information about your chosen trait. Include whether each person is male or female, does or does not have the trait, and the relationship of the individual to others in the family.
- 3 Use your information to draw a pedigree for the trait.
- 4 Try to determine the inheritance pattern of the trait you studied.

Analysis

1. **Classify** What trait did you study? Can you determine from your pedigree what the apparent inheritance pattern of the trait is?
2. **Critique** How is the study of inheritance patterns limited in pedigree analysis?

In a pedigree, a circle represents a female; a square represents a male. Shaded circles and squares represent individuals showing the trait being studied. Unshaded circles and squares designate individuals that do not show the trait. A half-shaded circle or square represents a **carrier**, a heterozygous individual. A horizontal line connecting a circle and a square indicates that the individuals are parents, and a vertical line connects parents with their offspring. Each horizontal row of circles and squares in a pedigree designates a generation, with the most recent generation shown at the bottom. The generations are identified in sequence by Roman numerals, and each individual is given an Arabic number. Practice using these symbols to make a pedigree in *MiniLab 12.1*.

Analyzing a pedigree

An example of a pedigree for a fictitious rare, recessive disorder in humans is shown in *Figure 12.2*. This genetic disorder could be any of several recessive disorders which shows up only if the affected person carries two recessive alleles for the trait. Follow this pedigree as you read how to analyze a pedigree.

Suppose individual III-1 in the pedigree wants to know the likelihood of passing on this allele to her children. By studying the pedigree, the individual will be able to determine the likelihood that she carries the allele. Notice that information can also be gained about other members of the family by studying the pedigree. For example, you know that I-1 and I-2 are both carriers of the recessive allele for the trait because they have produced II-3, who shows the recessive phenotype. If you drew a Punnett square for the mating of individuals I-1 and I-2, you would find, according to Mendelian segregation,

Figure 12.2

This pedigree shows how a rare, recessive allele is transmitted from generation to generation.

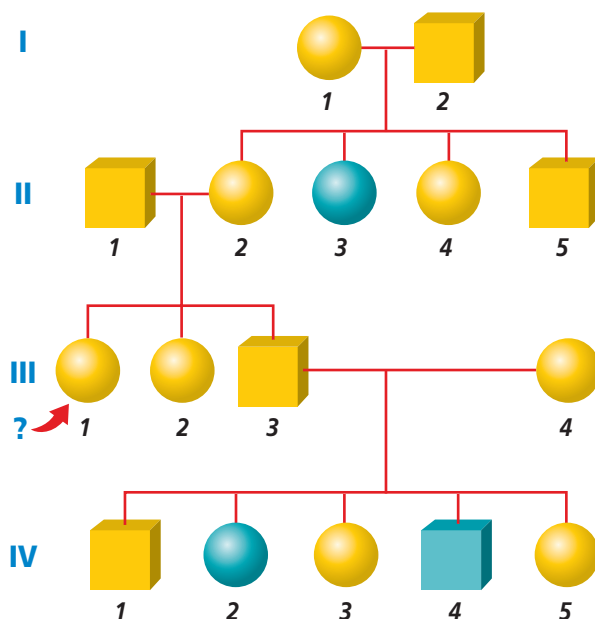

that the ratio of homozygous dominant to heterozygous to homozygous recessive genotypes among their children would be 1:2:1. Of those genotypes possible for the members of generation II, only the homozygous recessive genotype will express the trait, which is the case for II-3.

You can't tell the genotypes of II-4 and II-5, but they have a normal phenotype. If you look at the Punnett square you made, you can see that the probability that II-4 and II-5 are carriers is two in three for each because they can have only two possible genotypes—homozygous normal and heterozygous. The homozygous recessive genotype is not a possibility in these individuals because neither of them shows the affected phenotype.

Because none of the children in generation III are affected and because the recessive allele is rare in the general population, it is reasonably safe to assume that II-1 is not a carrier. You know that II-2 must be a carrier like her parents because she has passed on the recessive allele to subsequent generation IV. Because III-1 has one parent who is heterozygous and the other parent who is assumed to be homozygous normal, III-1 most likely has a one-in-two chance of being a carrier. If her parent II-1 had been heterozygous instead of homozygous normal, III-1's chances of being a carrier are increased to two in three.

Simple Recessive Heredity

Most genetic disorders are caused by recessive alleles. You can practice calculating the chance that offspring will be born with some of these genetic traits in the *Problem-Solving Lab* on this page.

Problem-Solving Lab 12.1

Apply Concepts

What are the chances? Using a Punnett square allows you to calculate the chance that offspring will be born with certain traits. In order to do this, however, you must first know the genotype of the parents and whether the trait that is being described is dominant or recessive.



Polydactyly—having six fingers

Solve the Problem

Use the following traits and their alleles to answer the questions below.

Human Traits		
Trait	Dominant Allele	Recessive Allele
Number of fingers	$D = \text{six}$	$d = \text{five}$
Cleft chin	$C = \text{cleft chin}$	$c = \text{no cleft chin}$
Earlobes	$F = \text{hanging}$	$f = \text{attached}$

Thinking Critically

- Use Numbers** What are the chances that a child will be born with six fingers if
 - both parents are heterozygous?
 - one parent has five fingers, the other is heterozygous?
 - both parents have five fingers?
- Use Numbers** Predict how many children in a family of four will have cleft chins if
 - one parent has a cleft chin and the other is homozygous for cleft chin.
 - both parents have cleft chins and both are homozygous.
 - both parents have cleft chins and each of them has a parent who has a cleft chin.
- Infer** A child is born with attached earlobes, but both parents have hanging earlobes.
 - What are the genotypes and phenotypes for the parents?
 - What is the genotype and phenotype for the child?

Cystic fibrosis

Cystic fibrosis (CF) is a fairly common genetic disorder among white Americans. Approximately one in 28 white Americans carries the recessive allele, and one in 2500 children born to white Americans inherits the disorder. Due to a defective protein in the plasma membrane, cystic fibrosis results in the formation and accumulation of thick mucus in the lungs and digestive tract. Physical therapy, special diets, and new drugs have continued to raise the average life expectancy of people that have CF.

Tay-Sachs disease

Tay-Sachs (tay saks) disease is a recessive disorder of the central nervous system. In this disorder, a recessive allele results in the absence of an enzyme that normally breaks down a

lipid produced and stored in tissues of the central nervous system. Because this lipid fails to break down properly, it accumulates in the cells. The allele for Tay-Sachs is especially common in the United States among Ashkenazic Jews, whose ancestors came from eastern Europe. **Figure 12.3** shows a typical pedigree for Tay-Sachs disease.

Phenylketonuria

Phenylketonuria (fen ul kee tun YOO ree uh), also called PKU, is a recessive disorder that results from the absence of an enzyme that converts one amino acid, phenylalanine, to a different amino acid, tyrosine. Because phenylalanine cannot be broken down, it and its by-products accumulate in the body and result in severe damage to the central nervous system. The PKU allele is most common in the United States among people whose ancestors came from Norway, Sweden, or Ireland.

A homozygous PKU newborn appears healthy at first because its mother's normal enzyme level prevented phenylalanine accumulation during development. However, once the infant begins drinking milk, which is rich in phenylalanine, the amino acid accumulates and mental retardation occurs. Today, a PKU test is normally performed on all infants a few days after birth. Infants affected by PKU are given a diet that is low in phenylalanine until their brains are fully developed. With this special diet, the toxic effects of the disorder can be avoided.

Ironically, the success of treating phenylketonuria infants has resulted in a new problem. If a female who is homozygous recessive for PKU becomes pregnant, the high phenylalanine levels in her blood can damage her **fetus**—the developing baby. This problem occurs even if the fetus is heterozygous and would be phenotypically normal.

Figure 12.3

A study of families who have children with Tay-Sachs disease shows typical pedigrees for traits inherited as simple recessives. Note that the trait appears to skip generations, a characteristic of a recessive trait.

Analyze *What is the genotype of individual II-3?*

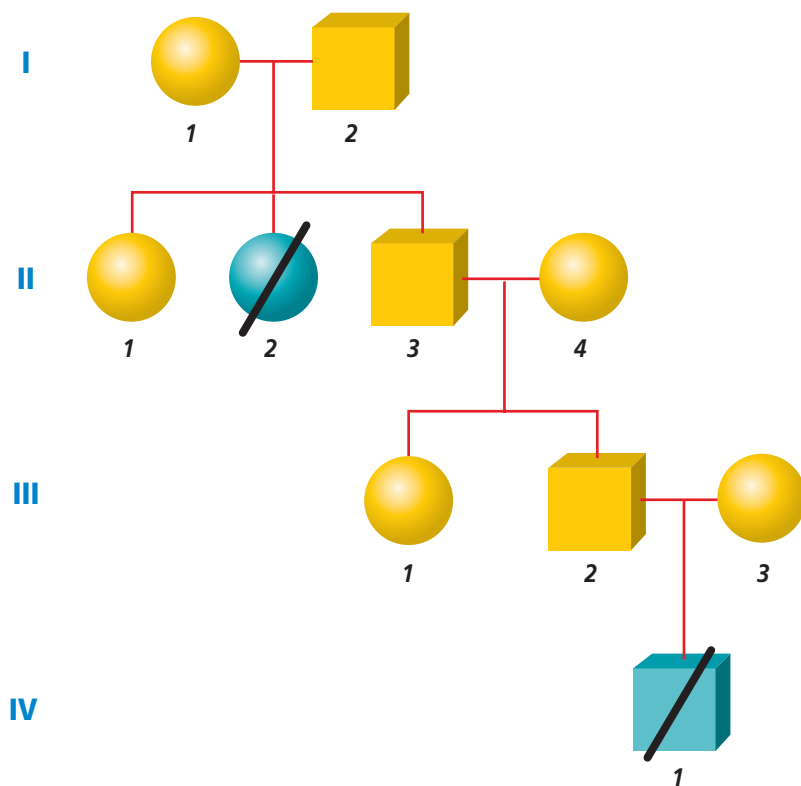



Figure 12.4

The allele F for freely hanging earlobes (A) is dominant to the allele f for attached earlobes (B). Having a pointed frontal hairline called a widow's peak (C), indicates that one or two dominant alleles for the trait have been inherited.



You may have noticed PKU warnings on cans of diet soft drinks. Because most diet foods are sweetened with an artificial sweetener that contains phenylalanine, a pregnant woman who is homozygous recessive must limit her intake of diet foods.

Simple Dominant Heredity

Unlike the inheritance of recessive traits in which a recessive allele must be inherited from both parents for a person to show the recessive phenotype, many traits are inherited just as the rule of dominance predicts. Remember that in Mendelian inheritance, a single dominant allele inherited from one parent is all that is needed for a person to show the dominant trait.

Simple dominant traits

A cleft chin is one example of a simple dominant trait. If you have a cleft chin, you've inherited the dominant allele from at least one of your parents. A widow's peak hairline and

earlobe types, shown in **Figure 12.4**, are other dominant traits that are determined by simple Mendelian inheritance. Having earlobes that are attached to the head is a recessive trait (ff), whereas heterozygous (Ff) and homozygous dominant (FF) individuals have earlobes that hang freely.

There are many other human traits that are inherited by simple dominant inheritance. **Figure 12.5** shows one of these traits—hitchhiker's thumb, the

Figure 12.5
Hitchhiker's thumb is a dominant trait.



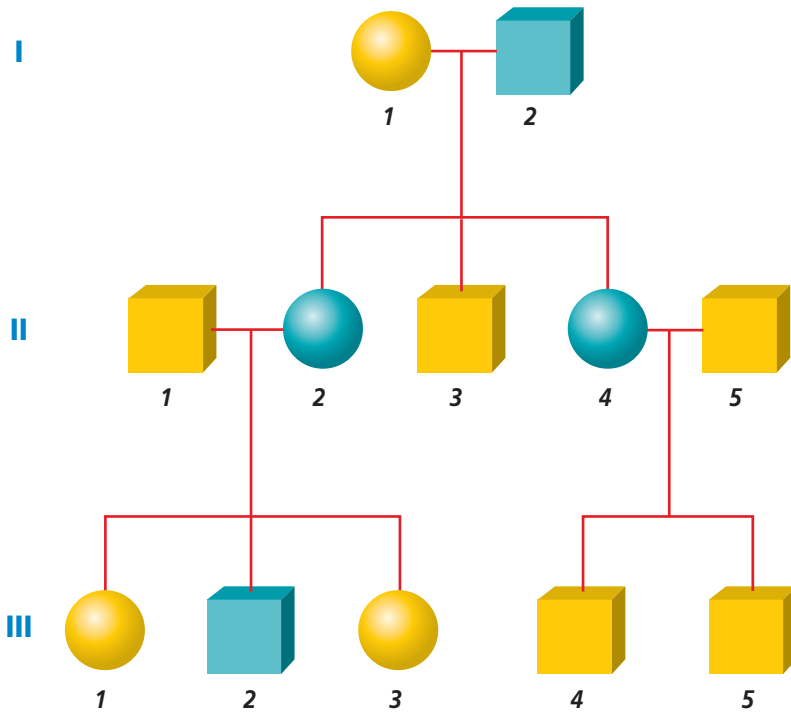

Figure 12.6

This is a typical pedigree for a simple, dominant inheritance of Huntington's disease. This particular chart shows the disorder in each generation and equally distributed among males and females.

ability to bend your thumb tip backward more than 30 degrees. A straight thumb is recessive. Other dominant traits in humans include almond-shaped eyes (round eyes are recessive), thick lips (thin lips are recessive), and the presence of hair on the middle section of your fingers.

Huntington's disease

Huntington's disease is a lethal genetic disorder caused by a rare dominant allele. It results in a breakdown of certain areas of the brain. No effective treatment exists.

Ordinarily, a dominant allele with such severe effects would result in death before the affected individual could have children and pass the allele on to the next generation. But because the onset of Huntington's disease usually occurs between the ages of 30 and 50, an individual may already have had children before knowing whether he or she is affected. A genetic test has been developed that detects the presence of this allele. Although this test allows individuals with the allele to decide whether they want to have children and risk passing the trait on to future generations, it also means that they know they will develop the disease. For this reason, some people may choose not to be tested. The pedigree in *Figure 12.6* shows a typical pattern for the occurrence of Huntington's disease in a family.

 **Reading Check** Predict the chance of an individual with Huntington's disease having an affected child if the other parent is unaffected.

Section Assessment

Understanding Main Ideas

1. In your own words, define the following symbols used in a pedigree: a square, a circle, an unshaded circle, a shaded square, a horizontal line, and a vertical line.
2. Describe one genetic disorder that is inherited as a recessive trait.
3. How are the cause and onset of symptoms of Huntington's disease different from those of PKU and Tay-Sachs disease?
4. Describe one trait that is inherited as a dominant allele. If you carried that trait, would you necessarily pass it on to your children?

Thinking Critically

5. Suppose that a child with free-hanging earlobes has a mother with attached earlobes. Can a man with attached earlobes be the child's father?

SKILL REVIEW

6. **Interpret Scientific Illustrations** Make and interpret a pedigree for three generations of a family that shows at least one member of each generation who demonstrates a particular trait. Would this trait be dominant or recessive? For more help, refer to *Interpret Scientific Illustrations* in the **Skill Handbook**.



Section 12.2

SECTION PREVIEW

Objectives

Distinguish between alleles for incomplete dominance and codominance.

Explain the patterns of multiple allelic and polygenic inheritance.

Analyze the pattern of sex-linked inheritance.

Summarize how internal and external environments affect gene expression.

Review Vocabulary

allele: an alternative form of a gene (p. 256)

New Vocabulary

incomplete dominance
codominant allele
multiple allele
autosome
sex chromosome
sex-linked trait
polygenic inheritance

When Heredity Follows Different Rules

Breaking the Rules

Using Prior Knowledge

Exceptions to the pattern of inheritance explained by Mendel became known soon after his work was rediscovered. Kernel color in corn is one of those exceptions. Today, geneticists know that most traits do not follow Mendel's simple rules of inheritance. Examine the photo of Indian corn to the right, and think about why the inheritance of kernel color in corn breaks Mendel's rules.

Analyze What clue in the photo made you think that the inheritance of kernel color in corn is not simple Mendelian?



Indian corn

Complex Patterns of Inheritance

Patterns of inheritance that are explained by Mendel's experiments are often referred to as simple Mendelian inheritance—inheritance controlled by dominant and recessive paired alleles. However, many inheritance patterns are more complex than those studied by Mendel. As you will learn, most traits are not simply dominant or recessive. The *BioLab* at the end of this chapter investigates a type of inheritance that doesn't even involve chromosomes.

Incomplete dominance: Appearance of a third phenotype

When inheritance follows a pattern of dominance, heterozygous and homozygous dominant individuals both have the same phenotype. When traits are inherited in an **incomplete dominance** pattern, however, the phenotype of heterozygous individuals is intermediate between those of the two homozygotes. For example, if a homozygous red-flowered snapdragon plant (RR) is crossed with a homozygous white-flowered snapdragon plant ($R'R'$), all of the F_1 offspring will have pink flowers.

Figure 12.7

A Punnett square of snapdragon color shows that the red-flowered snapdragon is homozygous for the allele R , and the white-flowered snapdragon is homozygous for the allele R' . All of the pink-flowered snapdragons are heterozygous, or RR' .

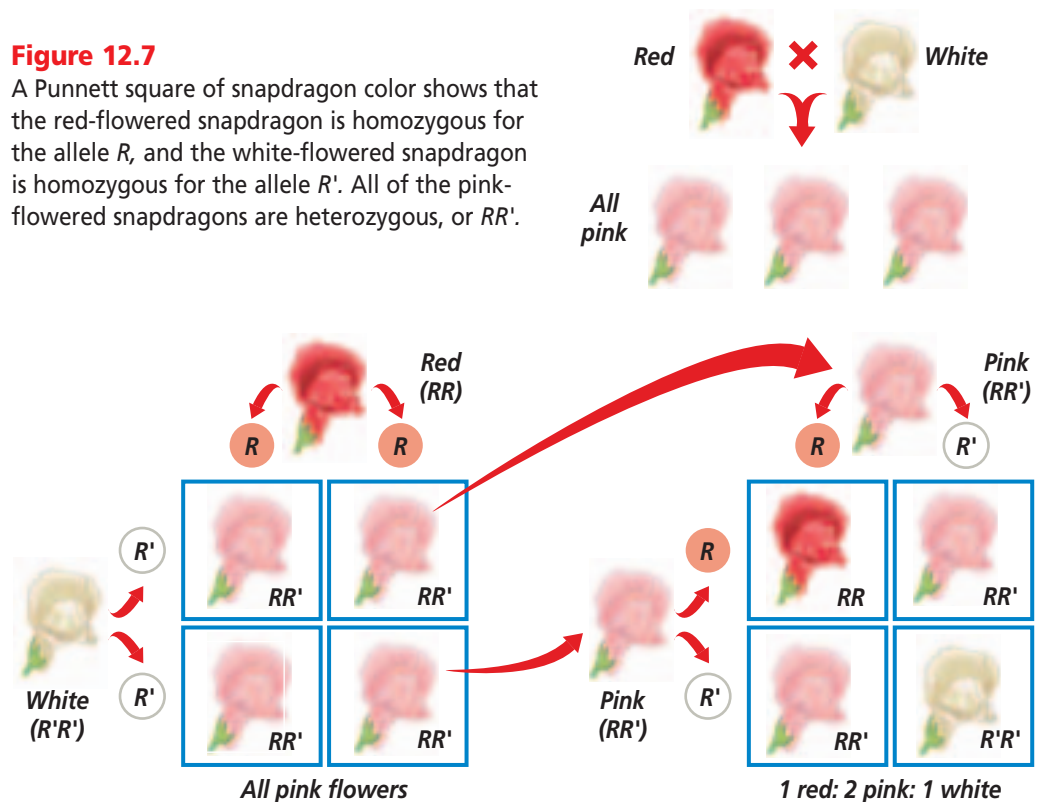

Figure 12.7 shows that the intermediate pink form of the trait occurs because neither allele of the pair is completely dominant. Note that the letters R and R' , rather than R and r , are used to show incomplete dominance.

The new phenotype occurs because the flowers contain enzymes that control pigment production. The R allele codes for an enzyme that produces a red pigment. The R' allele codes for a defective enzyme that makes no pigment. Because the heterozygote has only one copy of the R allele, its flowers appear pink because they produce only half the amount of red pigment that red homozygote flowers produce. The $R'R'$ homozygote has no normal enzyme, produces no red pigment, and appears white.

Note that the segregation of alleles is the same as in simple Mendelian inheritance. However, because neither allele is dominant, the plants of the F_1 generation all have pink flowers. When pink-flowered F_1 plants are crossed with each other, the offspring

in the F_2 generation appear in a 1:2:1 phenotypic ratio of red to pink to white flowers. This result supports Mendel's law of segregation.

Reading Check Explain why snapdragon heterozygotes have flowers with an intermediate color.

Codominance: Expression of both alleles

In chickens, black-feathered and white-feathered birds are homozygotes for the B and W alleles, respectively. Two different uppercase letters are used to represent the alleles in codominant inheritance.

One of the resulting heterozygous offspring in a breeding experiment between a black rooster and a white hen is shown in **Figure 12.8**. You might expect that heterozygous chickens, BW , would be black if the pattern of inheritance followed Mendel's law of dominance, or gray if the trait were incompletely dominant. Notice, however, that the heterozygote is neither

black nor gray. Instead, all of the offspring are checkered; some feathers are black and other feathers are white. In such situations, the inheritance pattern is said to be codominant. **Codominant alleles** cause the phenotypes of both homozygotes to be produced in heterozygous individuals. In codominance, both alleles are expressed equally.

Multiple phenotypes from multiple alleles

Although each trait has only two alleles in the patterns of heredity you have studied thus far, it is common for more than two alleles to control a trait in a population. This is understandable when you recall that a new allele can be formed any time a mutation occurs in a nitrogenous base somewhere within a gene. Although only two alleles of a gene can exist within an individual diploid cell, multiple alleles for a single gene can be studied in a population of organisms.

Traits controlled by more than two alleles have **multiple alleles**.



Figure 12.8

When a certain variety of black chicken is crossed with a white chicken, all of the offspring are checkered. Both feather colors are produced by codominant alleles. **Think Critically** *What color would the chicken be if feather color were inherited by incomplete dominance?*

The pigeons pictured in *Figure 12.9* show the effects of multiple alleles for feather color. Three alleles of one gene govern their feather color, although each pigeon can have only two of these alleles. The number of alleles for any particular trait is not limited to three, and there are instances in which more than 100 alleles are known to exist for a single trait! You can learn about another example of multiple alleles in the *Problem-Solving Lab* on the next page.

Figure 12.9

In pigeons, one gene that controls feather color has three alleles. An enzyme that activates the production of a pigment is controlled by the B allele. This enzyme is lacking in bb pigeons.

A The dominant B^A allele produces ash-red colored feathers.

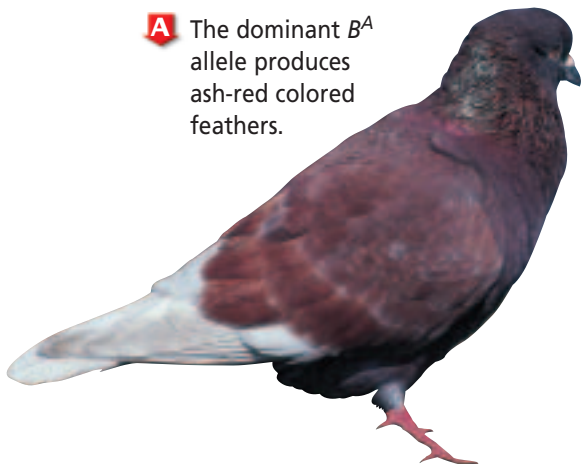

B The B allele produces wild-type blue feathers. B is dominant to b but recessive to B^A .



C The allele b produces a chocolate-colored feather and is recessive to both other alleles.

Problem-Solving Lab 12.2

Predict

How is coat color in rabbits inherited? Coat color in rabbits is inherited as a series of multiple alleles. This means that there can be more than just two alleles for a gene. In the case of coat color in rabbits, there are four alleles, and each one is expressed with a different phenotype.

Solve the Problem

Examine the table below. Use this information to answer the questions. Remember, each rabbit can have only two alleles for coat color.

Coat Color in Rabbits		
Phenotype	Allele	Pattern of Inheritance
Dark gray coat	C	Dominant to all other alleles
Chinchilla	c^{ch}	Dominant to Himalayan and to white
Himalayan	c^h	Dominant to white
White	c	Recessive

Thinking Critically

- Classify** List all possible genotypes for a
 - dark gray-coated rabbit (there are 4).
 - chinchilla rabbit (there are 3).
 - Himalayan rabbit (there are 2).
 - white rabbit (there is 1).
- Predict** What is the phenotype for a rabbit with a $c^h c^{ch}$ and a rabbit with a $C c^{ch}$ genotype? Explain.
- Explain** Would it be possible to obtain white rabbits if one parent is white and the other is chinchilla? Explain.
- Analyze** Is it possible to obtain chinchilla rabbits if one parent is Himalayan and the other is white? Explain.

Sex determination

Recall that in humans the diploid number of chromosomes is 46, or 23 pairs. There are 22 pairs of homologous chromosomes called **autosomes**. Homologous autosomes look alike. The 23rd pair of chromosomes differs in males and females. These two chromosomes, which determine the sex of an individual, are called **sex chromosomes** and are indicated by the letters X and Y. If you are female, your 23rd pair of chromosomes are homologous, XX, as in *Figure 12.10A*. However, if you are male, your 23rd pair of chromosomes, XY, look different. Males usually have one X and one Y chromosome and produce two kinds of gametes, X and Y. Females usually have two X chromosomes and produce only X gametes. It is the male gamete that determines the sex of the offspring. *Figure 12.10B* shows that after fertilization, a 1:1 ratio of males to females is expected. Because fertilization is governed by the laws of probability, the ratio usually is not exactly 1:1 in a small population.

Sex-linked inheritance

Drosophila (droh SAH fuh luh), commonly known as fruit flies, inherit sex chromosomes in the same way as humans. Traits controlled by genes

Figure 12.10

The sex chromosomes in humans are called X and Y. **Analyze** Which parent determines the sex of the offspring?

A The sex chromosomes are named for the letters they resemble.

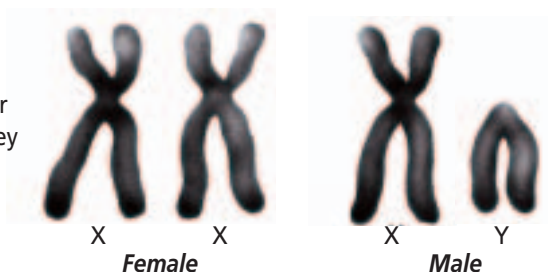

B The offspring of any mating between humans will have a 50-50 chance of having two X chromosomes, XX, which is female, or of having one X and one Y chromosome, XY, which is male.

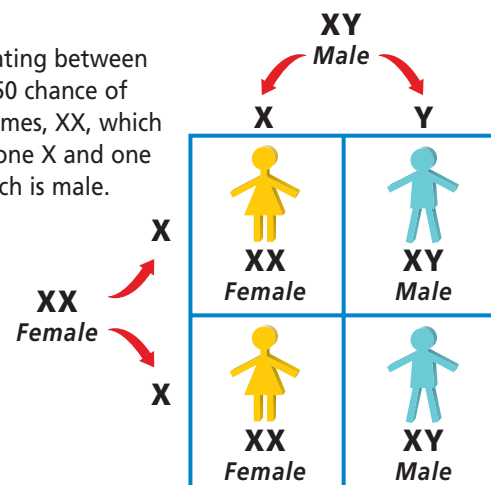

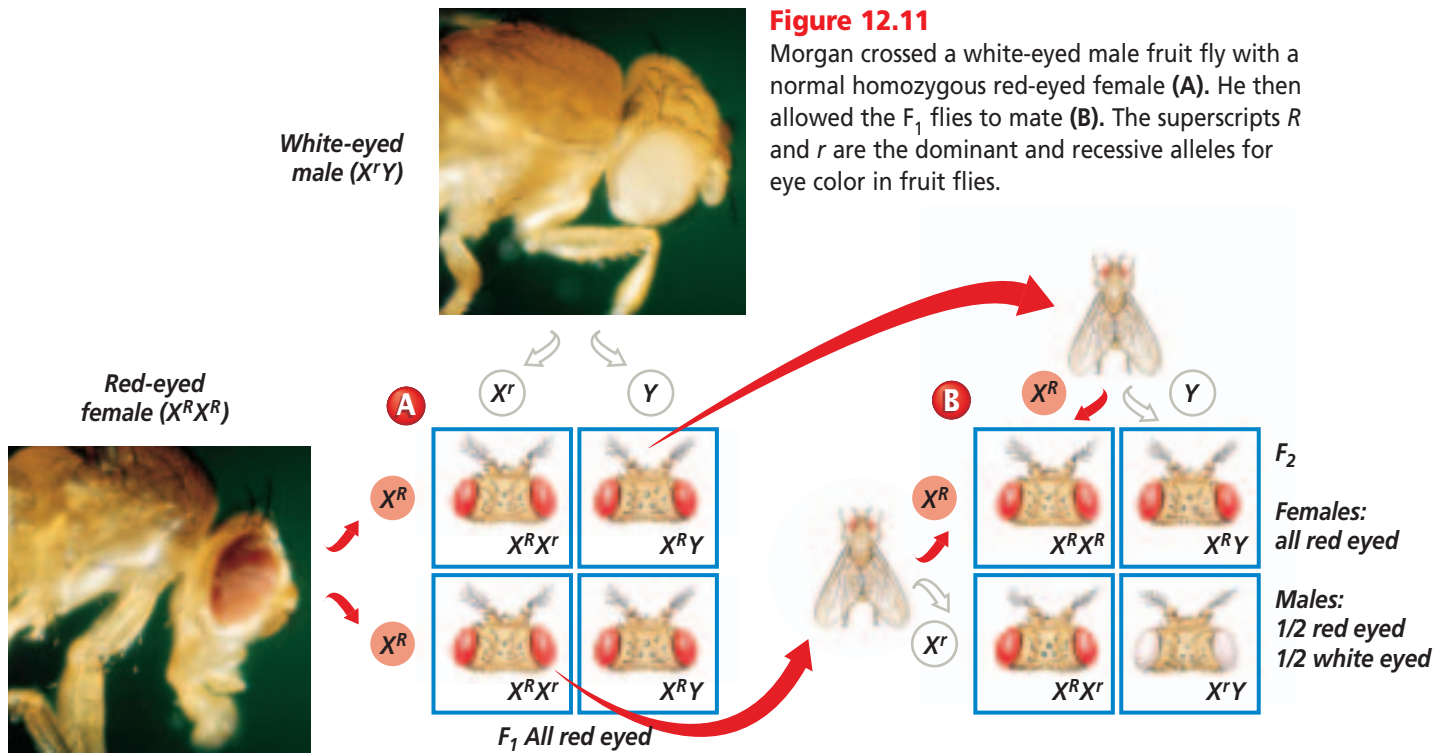

Figure 12.11

Morgan crossed a white-eyed male fruit fly with a normal homozygous red-eyed female (A). He then allowed the F₁ flies to mate (B). The superscripts R and r are the dominant and recessive alleles for eye color in fruit flies.

located on sex chromosomes are called **sex-linked traits**. The alleles for sex-linked traits are written as superscripts of the X or Y chromosome. Because the X and Y chromosomes are not homologous, the Y chromosome has no corresponding allele to one on the X chromosome and no superscript is used. Also remember that any recessive allele on the X chromosome of a male will not be masked by a corresponding dominant allele on the Y chromosome.

In 1910, Thomas Hunt Morgan discovered traits linked to sex chromosomes. Morgan noticed one day that one male fly had white eyes rather than the usual red eyes. He crossed the white-eyed male with a homozygous red-eyed female. All of the F₁ offspring had red eyes, indicating that the white-eyed trait is recessive. Then Morgan allowed the F₁ flies to mate among themselves. According to simple Mendelian inheritance, if the trait were recessive, the offspring in the F₂ generation

would show a 3:1 ratio of red-eyed to white-eyed flies. As you can see in **Figure 12.11**, this is what Morgan observed. However, he also noticed that the trait of white eyes appeared only in male flies.

Morgan hypothesized that the red-eye allele was dominant and the white-eye allele was recessive. He also reasoned that the gene for eye color was located on the X chromosome and was not present on the Y chromosome. In heterozygous females, the dominant allele for red eyes masks the recessive allele for white eyes. In males, however, a single recessive allele is expressed as a white-eyed phenotype. When Morgan crossed a heterozygous red-eyed female with a white-eyed male, half of all the males and half of all the females inherited white eyes. The only explanation of these results is Morgan's hypothesis: The allele for eye color is carried on the X chromosome and the Y chromosome has no corresponding allele for eye color.

Word Origin

polygenic from the Greek words *polys*, meaning "many," and *genos*, meaning "kind"; Polygenic inheritance involves many genes.

The genes that govern sex-linked traits follow the inheritance pattern of the sex chromosome on which they are found. Eye color in fruit flies is an example of an X-linked trait. Y-linked traits are passed only from a male to male offspring because the genes for these traits are on the Y chromosome.

Polygenic inheritance

Some traits, such as skin color and height in humans, and cob length in corn, vary over a wide range. Such ranges occur because these traits are governed by many genes. **Polygenic inheritance** is the inheritance pattern of a trait that is controlled by two or more genes. The genes may be on the same chromosome or on different chromosomes, and each gene may have two or more alleles. For simplicity, uppercase and lowercase letters are used to represent the alleles, as they are in Mendelian inheritance. Keep in mind, however, that the allele represented by an uppercase letter is not dominant. All heterozygotes are intermediate in phenotype.

In polygenic inheritance, each allele represented by an uppercase letter contributes a small, but equal, portion to the trait being expressed. The result is that the phenotypes usually show a continuous range of variability from the minimum value of the trait to the maximum value.

Suppose, for example, that stem length in a plant is controlled by three different genes: *A*, *B*, and *C*. Each gene is on a different chromosome and has two alleles, which can be represented by uppercase or lowercase letters. Thus, each diploid plant has a total of six alleles for stem length. A plant that is homozygous for short alleles at all three gene locations (*aabbcc*) might grow to be only 4 cm tall, the base height. A plant that is homozygous for tall alleles at all three gene locations (*AABBCC*) might be 16 cm tall. The difference between the tallest possible plant and the shortest possible plant is 12 cm, or 2 cm per each tall allele.

Suppose a 16-cm-tall plant were crossed with a 4-cm-tall plant. In the F_1 generation, all offspring would be *AaBbCc*. If each tall gene *A*, *B*, and *C* contributed 2 cm of height to the base height of 4 cm, the expected height of these plants would be 10 cm (4 cm + 6 cm)—an intermediate height. If they are allowed to interbreed, the F_2 offspring will show a range of heights. A Punnett square of this trihybrid cross would show that 10-cm-tall plants are most often expected, and the tallest and shortest plants are seldom expected. Notice in *Figure 12.12* that when these results are graphed, the shape of the graph confirms the prediction of the Punnett square.

Figure 12.12

In this example of polygenic inheritance, three genes each have two alleles that contribute to the trait. When the distribution of plant heights is graphed, a bell-shaped curve is formed. Intermediate heights occur most often.

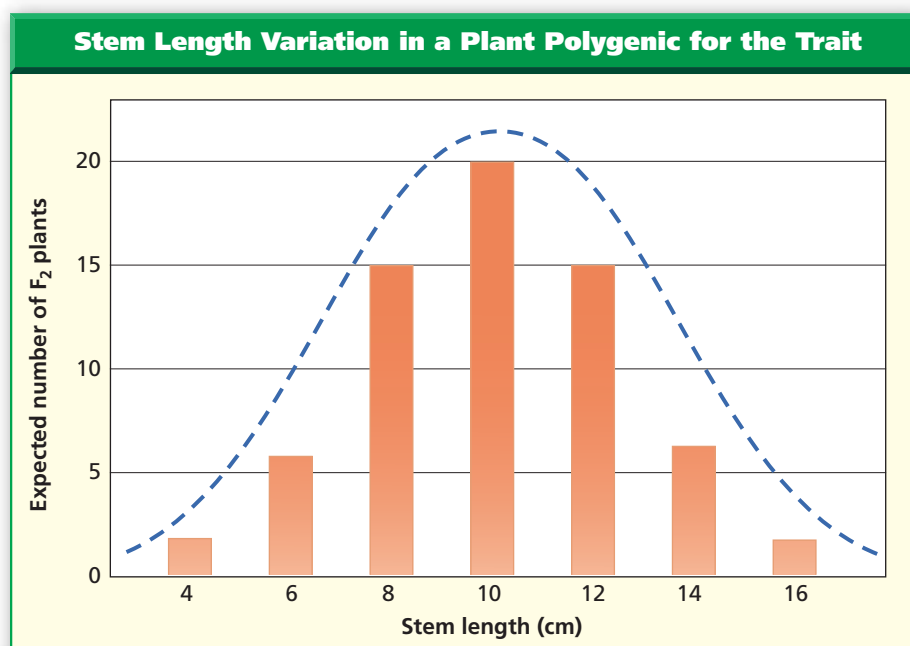



Figure 12.13

The arctic fox has gray-brown fur in warm temperatures. When temperatures fall, however, the fur becomes white. Think Critically *Why is white fur an adaptive advantage in winter?*

(t)Eastcott/Momatluk/Animals Animals, (r)Ralph Reinhold/Animals Animals, (b)Frank Oberle/ImageQuest

Environmental Influences

Even when you understand dominance and recessiveness, and you have solved the puzzles of the other patterns of heredity, the inheritance picture is not complete. The genetic makeup of an organism at fertilization determines only the organism's potential to develop and function. As the organism develops, many factors can influence how the gene is expressed, or even whether the gene is expressed at all. Two such influences are the organism's external and internal environments.

Influence of external environment

Sometimes, individuals known to have a particular gene fail to express the phenotype specified by that gene. Temperature, nutrition, light, chemicals, and infectious agents all can influence gene expression. In Siamese

cats and arctic foxes, as shown in *Figure 12.13*, temperature has an effect on the expression of coat color. External influences can also be seen in leaves. Leaves can have different sizes, thicknesses, and shapes depending on the amount of light they receive.

Influence of internal environment

The internal environments of males and females are different because of hormones and structural differences. For example, horn size in mountain sheep is expressed differently in males and females, as shown in *Figure 12.14*.



Figure 12.14

The horns of a ram (male) are much heavier and more coiled than those of a ewe (female) although their genotypes for horn size are identical.

Figure 12.15

Some traits are expressed differently in the sexes.

A The plumage of the male peacock is highly decorated and colored.



B The plumage of the female peahen is dull by comparison.



C Human male-pattern baldness, premature baldness that occurs in a characteristic pattern, is dominant in males but recessive in females.

Male-pattern baldness in humans, and feather color in peacocks also are expressed differently in the sexes, as shown in *Figure 12.15*. These differences are controlled by different hormones, which are determined by different sets of genes.

An organism's age can also affect gene function. The nature of such a pattern is not well understood, but it is

known that the internal environment of an organism changes with age.

Understanding how genes interact with each other and with the environment gives a more complete picture of inheritance. Mendel's idea that heredity is a composite of many individual traits still holds. Later researchers have filled in more details of Mendel's great contributions.

Section Assessment

Understanding Main Ideas

1. A cross between a purebred animal with red hairs and a purebred animal with white hairs produces an animal that has both red hairs and white hairs. What type of inheritance pattern is involved?
2. If a white-eyed male fruit fly were crossed with a heterozygous red-eyed female fruit fly, what ratio of genotypes would be expected in the offspring?
3. A red-flowered plant is crossed with a white-flowered plant. All of the offspring are pink. What inheritance pattern is expressed?
4. The color of wheat grains shows variability between red and white with multiple phenotypes. What is the inheritance pattern?

Thinking Critically

5. Armadillos always have four offspring that have identical genetic makeups. Suppose that, within a litter, each young armadillo is found to have a different phenotype for a particular trait. How could you explain this?

Skill Review

6. **Hypothesize** A population of a plant species in a meadow consists of plants that produce red, yellow, white, pink, or purple flowers. Hypothesize what the inheritance pattern is. For more help, refer to *Hypothesize* in the *Skill Handbook*.



Section 12.3

SECTION PREVIEW

Objectives

Identify codominance, multiple allelic, sex-linked, and polygenic patterns of inheritance in humans.

Distinguish among conditions that result from extra autosomal or sex chromosomes.

Review Vocabulary

homozygous: having two identical alleles for a particular gene (p. 258)

New Vocabulary

karyotype

Complex Inheritance of Human Traits

It's Not So Simple

Finding Main Ideas Have you ever thought about which of your traits came from your father or mother? Perhaps you can see one of your traits in a grandparent or another relative. As scientists study traits such as height and eye color, they are discovering that the inheritance of these traits can be very complex.

Organize Information As you read this section, make a list of some physical characteristics that appear in your family members or friends. Try to determine how each trait is inherited by examining its inheritance pattern.



The inheritance of eye color and height is complex.

Codominance in Humans

Remember that in codominance, the phenotypes of both homozygotes are produced in the heterozygote. One example of this in humans is a group of inherited red blood cell disorders called sickle-cell anemia.

Sickle-cell anemia

Sickle-cell anemia is a major health problem in the United States and in Africa. In the United States, it is most common in black Americans whose families originated in Africa and in white Americans whose families originated in the countries surrounding the Mediterranean Sea. About one in 12 African Americans, a much larger proportion than in most populations, is heterozygous for the disorder.

In an individual who is homozygous for the sickle-cell allele, the oxygen-carrying protein hemoglobin differs by one amino acid from normal hemoglobin. This defective hemoglobin forms crystal-like structures that change the shape of the red blood cells. Normal red blood cells are disc-shaped, but abnormal red blood cells are shaped like a sickle, or half-moon.

The change in shape occurs in the body's narrow capillaries after the hemoglobin delivers oxygen to the cells. Abnormally shaped blood cells, like the one shown in **Figure 12.16A**, slow blood flow, block small vessels, and result in tissue damage and pain. Because sickled cells block blood flow and have a shorter life span than normal red blood cells, the person can have several related disorders.

Individuals who are heterozygous for the allele produce both normal and sickled hemoglobin, an example of codominance. They produce enough normal hemoglobin that they do not have the serious health problems of those homozygous for the allele and can lead relatively normal

lives. Individuals who are heterozygous are said to have the sickle-cell trait because they can show some signs of sickle-cell-related disorders if the availability of oxygen is reduced.

Multiple Alleles Govern Blood Type

You have learned that more than two alleles of a gene are possible for certain traits. Mendel's laws of heredity also can be applied to traits that have more than two alleles. The ABO blood group is a classic example of a single gene that has multiple alleles in humans.

Human blood types, listed in the table in **Figure 12.17**, are determined by the presence or absence of certain molecules on the surfaces of red blood cells. As the determinant of blood types A, B, AB, and O, the gene *I* has three alleles: I^A , I^B , and *i*. Study the table to see the genotypes of the different blood types.

The importance of blood typing

Determining blood type is necessary before a person can receive a blood transfusion because the red blood cells of incompatible blood types could clump together, causing death. Blood typing also can be helpful in solving cases of disputed parentage. For example, if a child has type AB blood and his or her mother has type A, a man with type O blood could not possibly be the father. But blood tests cannot prove that a certain man definitely is the father; they indicate only that he could be. DNA tests are necessary to determine actual parenthood.

 **Reading Check** Determine the possible blood types of the children of parents that both have type AB.

Figure 12.16

In sickle-cell anemia, the gene for hemoglobin produces a protein that is different by one amino acid. This hemoglobin crystallizes when oxygen levels are low, changing the red blood cells into a sickle shape (A). A normal red blood cell is disc-shaped (B).

A

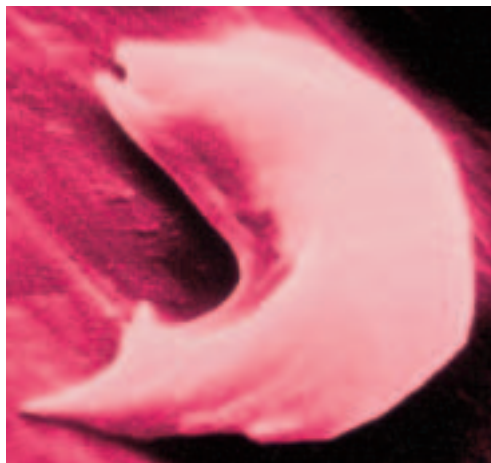

Color-enhanced SEM Magnification: 18 000X

B

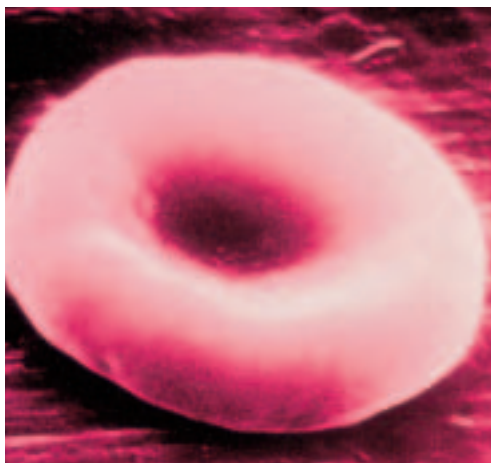

Color-enhanced SEM Magnification: 18 000X

The ABO Blood Group

Figure 12.17

The gene for blood type, gene *I*, codes for a molecule that attaches to a membrane protein found on the surface of red blood cells. The I^A and I^B alleles each code for a different molecule. Your immune system recognizes the red blood cells as belonging to you. If cells with a different surface molecule enter your body, your immune system will attack them. **Critical Thinking** *If your blood is type O and your mother's blood is type A, what blood types could your father have?*

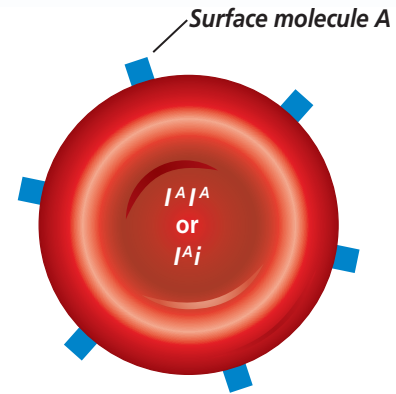

A Phenotype A The I^A allele is dominant to *i*, so inheriting either the I^A alleles or the $I^A I^A$ alleles from both parents will give you type A blood. Surface molecule A is produced.

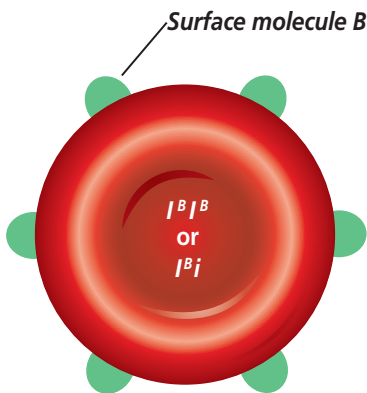

B Phenotype B The I^B allele is also dominant to *i*. To have type B blood, you must inherit the I^B allele from one parent and either another I^B allele or the *i* allele from the other. Surface molecule B is produced.

C Phenotype AB The I^A and I^B alleles are codominant. This means that if you inherit the I^A allele from one parent and the I^B allele from the other, your red blood cells will produce both surface molecules and you will have type AB blood.

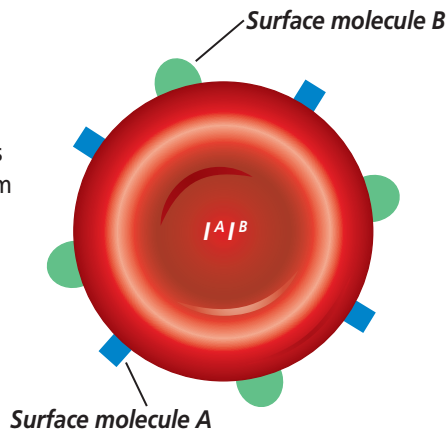

Color-enhanced SEM Magnification: 973X



Red blood cells

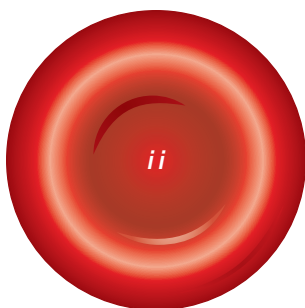

D Phenotype O The *i* allele is recessive and produces no surface molecules. Therefore, if you are homozygous *ii*, your blood cells have no surface molecules and you have blood type O.

Human Blood Types		
Genotypes	Surface Molecules	Phenotypes
$I^A I^A$ or $I^A i$	A	A
$I^B I^B$ or $I^B i$	B	B
$I^A I^B$	A and B	AB
<i>ii</i>	None	O

Figure 12.18

If a trait is X-linked, males pass the X-linked allele to all of their daughters but not to their sons (A). Heterozygous females have a 50 percent chance of passing a recessive X-linked allele to each child (B).

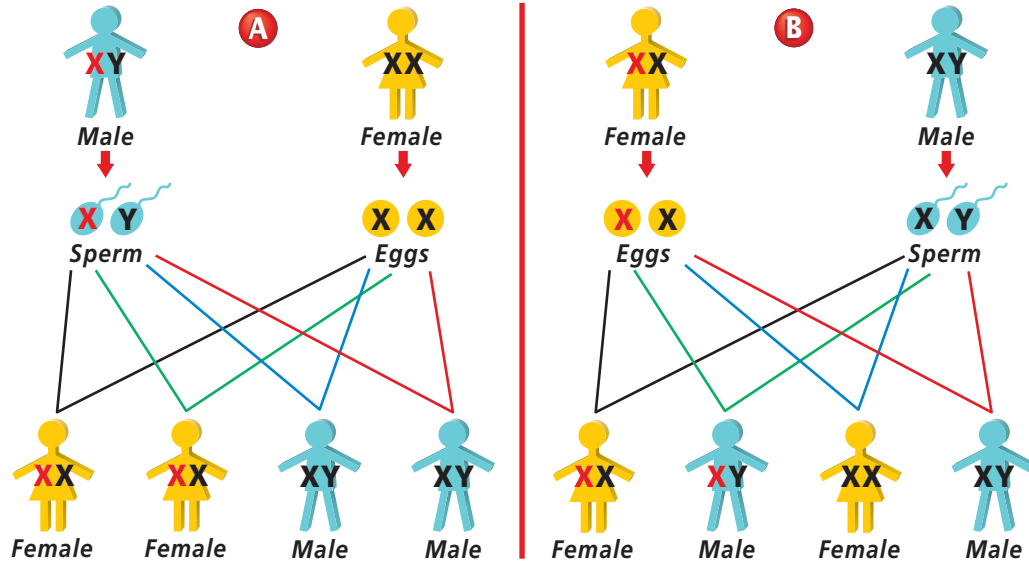

Problem-Solving Lab 12.3

Draw a Conclusion

How is Duchenne's muscular dystrophy inherited? Muscular dystrophy is a group of genetic disorders that produce muscular weakness, progressive deterioration of muscular tissue, and loss of coordination. Different forms of muscular dystrophy can be inherited as an autosomal dominant, an autosomal recessive, or a sex-linked disorder. These three patterns of inheritance appear different from one another when a pedigree is made. One form of muscular dystrophy, called Duchenne's muscular dystrophy, affects three in 10 000 American males.

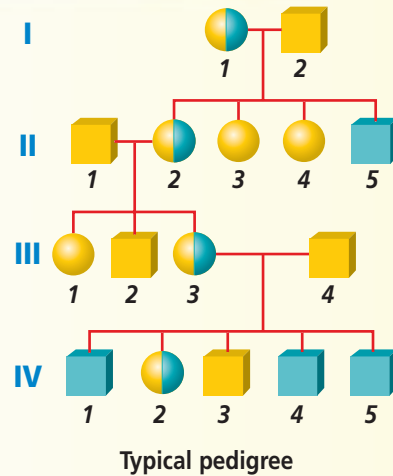

Solve the Problem

The pedigree shown here represents the typical inheritance pattern for Duchenne's muscular dystrophy. Refer to **Figure 12.1** if you need help interpreting the symbols. Analyze the pedigree above to determine the pattern of inheritance. Is this an autosomal or a sex-linked disorder?

Thinking Critically

Draw Conclusions If individual IV-1 had a daughter and a son, what would be the probability that the daughter is a carrier? That the son inherited the disorder?

Sex-Linked Traits in Humans

Many human traits are determined by genes that are carried on the sex chromosomes; most of these genes are located on the X chromosome. The pattern of sex-linked inheritance is explained by the fact that males, who are XY, pass an X chromosome to each daughter and a Y chromosome to each son. Females, who are XX, pass one of their X chromosomes to each child, as illustrated in **Figure 12.18**. If a son receives an X chromosome with a recessive allele, the recessive phenotype will be expressed because he does not inherit on the Y chromosome from his father a dominant allele that would mask the expression of the recessive allele.

Two traits that are governed by X-linked recessive inheritance in humans are red-green color blindness and hemophilia. X-linked dominant and Y-linked human disorders are rare. Determine whether Duchenne's muscular dystrophy is sex-linked by completing the *Problem-Solving Lab* on this page.

Red-green color blindness

People who have red-green color blindness can't differentiate these two colors. Color blindness is caused by the inheritance of a recessive allele at either of two gene sites on the X chromosome. Both genes affect red and green receptors in the cells of the eyes. A serious problem for people with this disorder is the inability to identify red and green traffic lights by color.

Hemophilia: An X-linked disorder

Did you ever notice that most cuts stop bleeding quickly? This human adaptation is essential. If your blood didn't have the ability to clot, any cut could take a long time to stop bleeding. Of greater concern would be internal bleeding resulting from a bruise, which a person may not immediately notice.

Hemophilia A is an X-linked disorder that causes such a problem with blood clotting. About one male in every 10 000 has hemophilia, but only about one in 100 million females inherits the same disorder. Why? Males inherit the allele for hemophilia on the X chromosome from their carrier mothers. One recessive allele for hemophilia will cause the disorder in males. Females would need two recessive alleles to inherit hemophilia. The family of Queen Victoria, pictured in the *Connection to Social Studies* at the end of this chapter, is the best-known study of hemophilia A, also called royal hemophilia.

Hemophilia A can be treated with blood transfusions and injections of Factor VIII, the blood-clotting enzyme that is absent in people affected by the condition. However, both treatments are expensive. New methods of DNA technology are being used to develop a cheaper source of the clotting factor.

MiniLab 12.2

Observe and Infer

Detecting Colors and Patterns in Eyes

Human eye color, like skin color, is determined by polygenic inheritance. You can detect several shades of eye color, especially if you look closely at the iris with a magnifying glass. Often, the pigment is deposited so that light reflects from the eye, causing the iris to appear blue, green, gray, or hazel (brown-green). In actuality, the pigment may be yellowish or brown, but not blue.

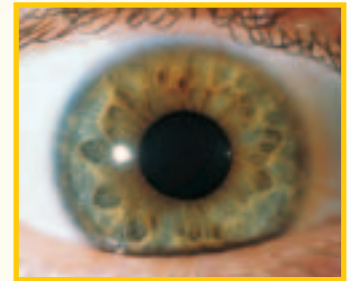

Hazel eye color

Procedure

CAUTION: Do not touch the eye with the magnifying glass or any other object.

- 1 Use a magnifying glass to observe the patterns and colors of pigment in the eyes of five classmates.
- 2 Use colored pencils to make drawings of the five irises.
- 3 Describe your observations in your journal.

Analysis

1. **Observe** How many different pigments were you able to detect in each eye?
2. **Critique** From your data, do you suspect that eye color might not be inherited by simple Mendelian rules? Explain.
3. **Analyze** Suppose that two people have brown eyes. They have two children with brown eyes, one with blue eyes, and one with green eyes. What pattern might this suggest?

Polygenic Inheritance in Humans

Think of all the traits you inherited from your parents. Although many of your traits were inherited through simple Mendelian patterns or through multiple alleles, many other human traits are determined by polygenic inheritance. These kinds of traits usually represent a range of variation that is measurable. The *MiniLab* on this page examines one of these traits—the color variations in human eyes.

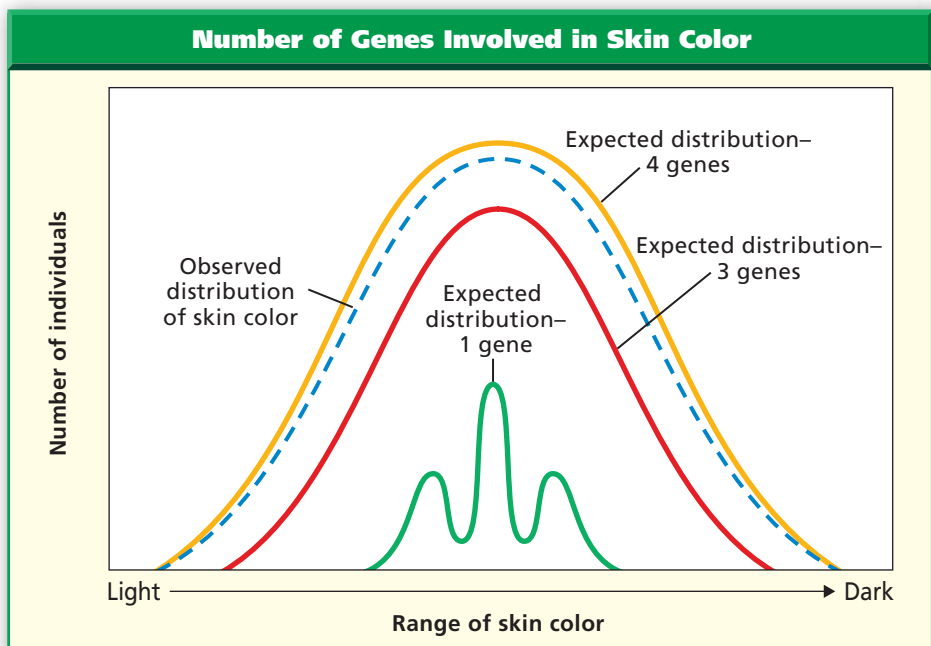

Figure 12.19

This graph (A) shows the expected distribution of human skin color if controlled by one, three, or four genes. The observed distribution of skin color (B) closely matches the distribution shown by four genes.

A



B

Skin color: A polygenic trait

In the early 1900s, the idea that polygenic inheritance occurs in humans was first tested using data collected on skin color. Scientists found that when light-skinned people mate with dark-skinned people, their offspring have intermediate skin colors. When these children produce the F_2 generation, the resulting skin colors range from the light-skin color to the dark-skin color of the grandparents (the P_1 generation), with most children having an intermediate skin color. As shown in *Figure 12.19*, the variation in skin color indicates that between three and four genes are involved.

Changes in Chromosome Numbers

You have been reading about traits that are caused by one or several genes on chromosomes. What would happen if an entire chromosome or part of a chromosome were missing

from the complete set? What if a cell's nucleus contained an extra chromosome? As you have learned, abnormal numbers of chromosomes in offspring usually, but not always, result from accidents of meiosis. Many abnormal phenotypic effects result from such mistakes.

Abnormal numbers of autosomes

You know that a human usually has 23 pairs of chromosomes, or 46 chromosomes altogether. Of these 23 pairs of chromosomes, 22 pairs are autosomes. Humans who have an extra whole or partial autosome are trisomic—that is, they have three of a particular autosomal chromosome instead of just two. In other words, they have 47 chromosomes. Recall that trisomy usually results from nondisjunction, which occurs when paired homologous chromosomes fail to separate properly during meiosis.

Word Origin

autosome from the Greek words *autos*, meaning "self," and *soma*, meaning "body"; An autosome is a chromosome that is not a sex chromosome.

To identify an abnormal number of chromosomes, a sample of cells is obtained from an individual or from a fetus. Metaphase chromosomes are photographed; the chromosome pictures are then enlarged and arranged in pairs by a computer according to length and location of the centromere, as shown in *Figure 12.20*. This chart of chromosome pairs is called a **karyotype**, and it is valuable in identifying unusual chromosome numbers in cells.



Figure 12.20

This karyotype demonstrates XYY syndrome, where two Y chromosomes are inherited from the father instead of just one Y chromosome. Infer **What sex is an XYY individual?**

Down syndrome: Trisomy 21

Most human abnormal chromosome numbers result in embryo death often before a woman even realizes she is pregnant. Fortunately, these rarely occur. Down syndrome is the only autosomal trisomy in which affected individuals survive to adulthood. It occurs in about one in 700 live births.

Down syndrome is a group of symptoms that results from trisomy of chromosome 21. Individuals who have Down syndrome have at least some degree of mental retardation. The incidence of Down syndrome births is higher in older mothers, especially those over 40.

Abnormal numbers of sex chromosomes

Many abnormalities in the number of sex chromosomes are known to exist. An X chromosome may be missing (designated as XO) or there may be an extra one (XXX or XXY). There may also be an extra Y chromosome (XYY), as you can see by examining *Figure 12.20*. Any individual with at least one Y chromosome is a male, and any individual without a Y chromosome is a female. Most of these individuals lead normal lives, but they cannot have children and some have varying degrees of mental retardation.

Section Assessment

Understanding Main Ideas

- Describe how a zygote with trisomy 21 is likely to occur during fertilization.
- In addition to revealing chromosome abnormalities, what other information about an individual would a karyotype show?
- What would the genotypes of parents have to be for them to have a color-blind daughter? Explain.
- Describe a genetic trait in humans that is inherited as codominance. Describe the phenotypes of the two homozygotes and that of the heterozygote. Why is this trait an example of codominance?

Thinking Critically

- A man is accused of fathering two children, one with type O blood and another with type A blood. The mother of the children has type B blood. The man has type AB blood. Could he be the father of both children? Explain your answer.

SKILL REVIEW

- Get the Big Picture** Construct a table of the traits discussed in this section. For column heads, use Trait, Pattern of inheritance, and Characteristics. For more help, refer to *Get the Big Picture* in the Skill Handbook.



DESIGN YOUR OWN

BioLab



Before You Begin

The mitochondria of all eukaryotes and the chloroplasts of plants and algae contain DNA. This DNA is not in chromosomes, but it still carries genes. Many of the mitochondrial genes control steps in the respiration process.

The genes in chloroplasts control traits such as chlorophyll production. Lack of chlorophyll in some cells causes the appearance of white patches in a leaf. This trait is known as variegated leaf. In this BioLab, you will carry out an experiment to determine the pattern of inheritance of the variegated leaf trait in *Brassica rapa*.

What is the pattern of cytoplasmic inheritance?

PREPARATION

Problem

What inheritance pattern does the variegated leaf trait in *Brassica rapa* show?

Hypotheses

Consider the possible evidence you could collect that would answer the problem question. Form a hypothesis with your group that you can test to answer the question, and write the hypothesis in your journal.

Objectives

In this BioLab, you will:

- **Determine** which crosses of *Brassica rapa* will reveal the pattern of cytoplasmic inheritance.
- **Analyze** data from *Brassica rapa* crosses.

Possible Materials

<i>Brassica rapa</i> seeds, normal	forceps
and variegated	single-edge razor blade
potting soil and trays	light source
paintbrushes	labels

Safety Precautions

CAUTION: *Always wear goggles in the lab. Handle the razor blade with extreme caution. Always cut away from you. Wash your hands with soap and water after working with plant material.*

Skill Handbook

If you need help with this lab, refer to the **Skill Handbook**.

PLAN THE EXPERIMENT

1. Decide which crosses will be needed to test your hypothesis.
2. Keep the available materials in mind as you plan your procedure. How many seeds will you need?
3. Record your procedure, and list the materials and quantities you will need.



- Assign a task to each member of the group. One person should write data in a journal, another can pollinate the flowers, while a third can set up the plant trays. Determine who will set up and clean up materials.
- Design and construct a data table.

Check the Plan

Discuss the following points with other group members to decide the final procedure for your experiment.

- What data will you collect, and how will it be recorded?
- When will you pollinate the flowers? How many flowers will you pollinate?
- How will you transfer pollen from one flower to another?
- How and when will you collect the seeds that result from your crosses?
- What variables will have to be controlled? What controls will be used?
- When will you end the experiment?
- Make sure your teacher has approved your experimental plan before you proceed further.*
- Carry out your experiment.
- CLEANUP AND DISPOSAL** Make wise choices in the disposal of materials.

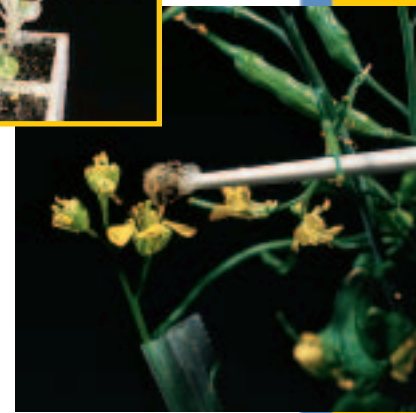

ANALYZE AND CONCLUDE

- Check Your Hypothesis** Did your data support your hypothesis? Why or why not?
- Interpret Observations** What is the inheritance pattern of variegated leaves in *Brassica rapa*?
- Make Inferences** Explain why genes in the chloroplast are inherited in this pattern.
- Draw Conclusions** Which parent passes the variegated trait to its offspring?
- Make Scientific Illustrations** Draw a diagram tracing the inheritance of this trait through cell division.
- ERROR ANALYSIS** What, besides genetics, might cause white leaves to form?

Apply Your Skill

Project Make crosses between normal *Brassica rapa* and genetically dwarfed, mutant *Brassica rapa* to determine the inheritance pattern of the dwarf mutation.



Web Links To find out more about inheritance of traits, visit bdol.glencoe.com/traits

Queen Victoria and Royal Hemophilia

One of the most famous examples of a pedigree demonstrating inheritance of a sex-linked trait is the family of Queen Victoria of England and hemophilia.

Queen Victoria had four sons and five daughters. Her son Leopold had hemophilia and died as a result of a minor fall. Two of her daughters, Alice and Beatrice, were carriers for the trait. The disorder was passed to royal families in Spain, Prussia (formerly a kingdom in Germany), and Russia over four generations.

The Spanish royal family Victoria's daughter Beatrice, a carrier for the trait, married Prince Henry of Battenberg, a descendent of Prussian royalty. Two of their sons inherited the trait, both dying before the age of 35. Her daughter, Victoria, was a carrier and married King Alfonso XIII of Spain, thus transmitting the allele to the Spanish royal family. Two of their sons died from hemophilia in their early thirties.

The Prussian royal family Alice, another of Victoria's daughters, married Louis IV of Hesse, a member of the Prussian royal family and related to Prince Henry of Battenberg. One of Alice's sons, Frederick, died at the age of three from hemophilia. One of her daughters, Irene, passed the trait to the next generation of Prussian royalty—two of her sons.

The Russian royal family Irene's sister and Queen Victoria's granddaughter, Alexandra, married Czar Nicholas II of Russia. Four healthy daughters were born, but the only male heir, Alexis, showed signs of bleeding and



Queen Victoria surrounded by her family

bruising at only six weeks of age. Having a brother, an uncle, and two cousins who had suffered from the disorder and died at early ages, you can imagine the despair Alexandra felt for her son and the future heir. In desperation, the family turned to Rasputin, a man who claimed to have healing abilities and used Alexis' illness for his own political power. The series of events surrounding Alexis and his hemophilia played a role in the downfall of the Russian monarchy.

The British throne today Queen Elizabeth II, the current British monarch, is descended from Queen Victoria's eldest son, Edward VII. Because he did not inherit the trait, he could not pass it on to his children. Therefore, the British monarchy today does not carry the recessive allele for hemophilia, at least not inherited from Queen Victoria.

Math in Biology

Use Numbers If you were the child of a female carrier for a sex-linked trait such as hemophilia, what would be your chances of carrying the trait?



To find out more about hemophilia, visit bdol.glencoe.com/social_studies

Chapter 12 Assessment

STUDY GUIDE

Section 12.1

Mendelian Inheritance of Human Traits

Key Concepts

- A pedigree is a family tree of inheritance.
- Most human genetic disorders are inherited as rare recessive alleles, but a few are inherited as dominant alleles.

Vocabulary

carrier (p. 310)
fetus (p. 312)
pedigree (p. 309)

Section 12.2

When Heredity Follows Different Rules

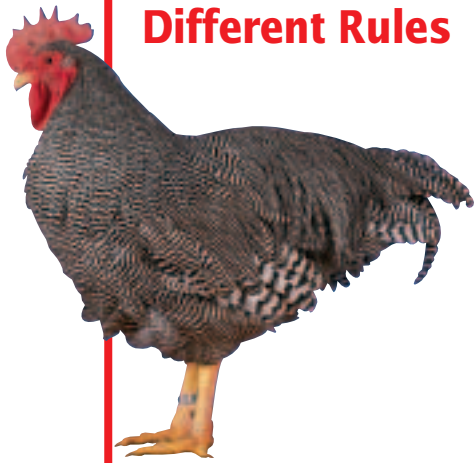

Key Concepts

- Some alleles can be expressed as incomplete dominance or codominance.
- There may be many alleles for one trait or many genes that interact to produce a trait.
- Cells have matching pairs of homologous chromosomes called autosomes.
- Sex chromosomes contain genes that determine the sex of an individual.
- Inheritance patterns of genes located on sex chromosomes are due to differences in the number and kind of sex chromosomes in males and in females.
- The expression of some traits is affected by the internal and external environments of the organism.

Vocabulary

autosome (p. 318)
codominant allele (p. 317)
incomplete dominance (p. 315)
multiple allele (p. 317)
polygenic inheritance (p. 320)
sex chromosome (p. 318)
sex-linked trait (p. 319)

Section 12.3

Complex Inheritance of Human Traits

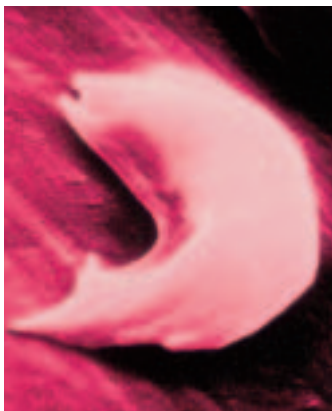

Color-enhanced SEM Magnification: 18 000X

Key Concepts

- The majority of human traits are controlled by multiple alleles or by polygenic inheritance. The inheritance patterns of these traits are highly variable.
- Sex-linked traits are determined by inheritance of sex chromosomes. X-linked traits are usually passed from carrier females to their male offspring. Y-linked traits are passed only from male to male.
- Nondisjunction may result in an abnormal number of chromosomes. Abnormal numbers of autosomes usually are lethal.
- A karyotype can identify unusual numbers of chromosomes in an individual.

Vocabulary

karyotype (p. 329)

FOLDABLES
Multi-Step

To help you review patterns of heredity, use the Organizational Study Fold on page 309.



Chapter 12 Assessment

Vocabulary Review

Review the Chapter 12 vocabulary words listed in the Study Guide on page 333. Determine if each statement is true or false. If false, replace the underlined word with the correct vocabulary word.

1. A carrier is always a heterozygous individual.
2. A pedigree is a chart showing the chromosome pairs of an individual.
3. In polygenic inheritance, there is a wide range of expression of a trait.
4. The phenotype of the heterozygote is intermediate for incomplete dominance.
5. Genes located on autosomes determine the sex of an individual.

Understanding Key Concepts

6. If a trait is X-linked, males pass the X-linked allele to _____ of their daughters.
A. all C. none
B. half D. $\frac{1}{4}$
7. Two parents with normal phenotypes have a daughter who has a genetically inherited disorder. This is an example of a(n) _____ trait in humans.
A. autosomal dominant
B. autosomal recessive
C. sex-linked
D. polygenic
8. Which of the following disorders would be inherited according to the pedigree shown here?
A. Tay-Sachs disease
B. sickle-cell anemia
C. cystic fibrosis
D. Huntington's disease
9. Which of the following disorders is likely to be inherited by more males than females?
A. Huntington's disease
B. Down syndrome
C. hemophilia
D. cystic fibrosis

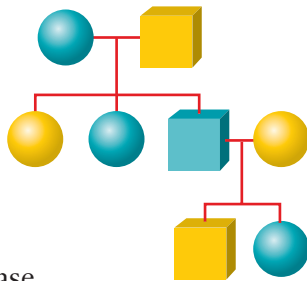

10. A karyotype reveals _____.
A. an abnormal number of genes
B. an abnormal number of chromosomes
C. polygenic traits
D. multiple alleles for a trait
11. A mother with blood type $I^B i$ and a father with blood type $I^A I^B$ have children. Which of the following genotypes would be possible for their children?
A. AB C. B
B. O D. A and C are correct
12. The genotype of the individual represented by this pedigree symbol is _____. Use the letters Y and y to represent alleles.
A. YY
B. Yy
C. yy
D. YYy

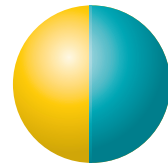

Constructed Response

13. **Open Ended** The brother of a woman's father has hemophilia. Her father was unaffected, but she worries that she may have an affected son. Should she worry? Explain.
14. **Open Ended** If a child has blood type O and its mother has type A, could a man with type B be the father? Why couldn't a blood test be used to prove that he is the father?
15. **Open Ended** Why do certain human genetic disorders, such as sickle-cell anemia, occur more frequently among one ethnic group than another?
16. **Open Ended** How can one gene mutation in a protein such as hemoglobin affect several body systems?

Thinking Critically

17. **Recognize Cause and Effect** Deletion of part of a chromosome may be lethal in a male but only cause a few problems in a female. Explain how that could be possible.



Chapter 12 Assessment

18. **Analyze** Infant X has blood type O, and infant Z has blood type A. Match the following parents with their child.

Father—blood type O;
 Mother—blood type AB.
 Father—blood type A;
 Mother—blood type B.

19. **REAL WORLD BIOCHALLENGE** Visit bdol.glencoe.com to find out more about the role hemophilia played in Russian history during the reign of Czar Nicholas II, especially in regards to Rasputin. Summarize your results in a multimedia presentation for your class.

Standardized Test Practice

All questions aligned and verified by



Part 1 Multiple Choice

Use the diagram to answer questions 20–22

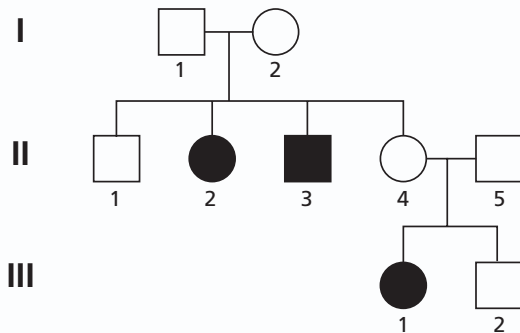

20. Which type of inheritance pattern is shown in the above pedigree?
 A. simple recessive
 B. simple dominant
 C. sex-linked inheritance
 D. codominance
21. What is individual II-4's genotype?
 A. *AA*
 B. *Aa*
 C. *aa*
 D. cannot be determined
22. How many different genotypes are possible for individual III-2?
 A. one
 B. two
 C. three
 D. cannot be determined

Study the karyotype and answer questions 23–25.

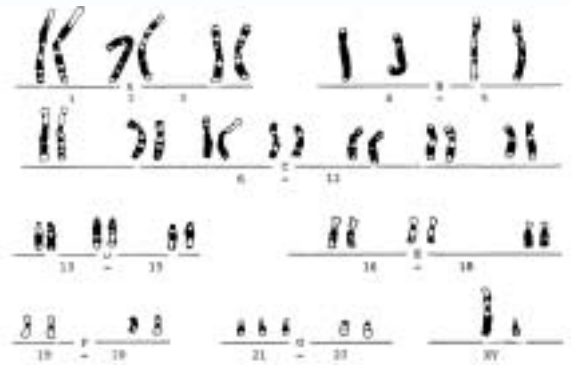

23. What is not normal about the above human karyotype?
 A. There are too many chromosome pairs.
 B. There are too few chromosome pairs.
 C. The sex chromosomes are not paired correctly.
 D. There are three number 21 chromosomes.
24. What is the name of the disorder displayed in the karyotype?
 A. Down syndrome
 B. Turner syndrome
 C. hemophilia
 D. sickle-cell anemia
25. What is the sex of this individual?
 A. male
 B. female
 C. cannot be determined
 D. abnormal

Part 2 Constructed Response/Grid In

Record your answers on your answer document.

26. **Open Ended** How does the inheritance of male-pattern baldness differ from other types of Mendelian inheritance?
27. **Open Ended** Explain why a male with a recessive X-linked trait usually produces no female offspring with the trait.

